

FSC-BT826F

4.2 Dual Mode Bluetooth Module Data Sheet

Document Type: FSC-BT826F

Document Version: V1.3

Release Date: 2022-09-28

Contact Us

Shenzhen Feasycom Co.,LTD

Email: sales@feasycom.com

Address: Rm 508, Building A, Fenghuang Zhigu, No.50, Tiezai Road, Xixiang, Baoan District, Shenzhen, 518102, China

Tel: 86-755-27924639

Release Record

Version Number	Release Date	Comments
Revision 1.0	2021-05-14	First Release
Revision 1.1	2021-10-27	change the Supply Voltage
Revision 1.2	2022-05-06	Add reset
Revision 1.3	2022-09-28	Update

Shenzhen Feasycom Co., LTD.



1. INTRODUCTION

FSC-BT826F is a fully integrated Bluetooth module that complies with Bluetooth 4.2 dual mode protocols(BR/EDR/BLE). It supports SPP, BLE, ANCS, iBeacon, profiles. It integrates Baseband controller in a small package (Integrated chip antenna), so the designers can have better flexibilities for the product shapes.

FSC-BT826F can be communicated by UART port. With Feasycom's Bluetooth stack, Customers can easily transplant to their software. Please refer to Feasycom stack design guide.

1.1 Block Diagram

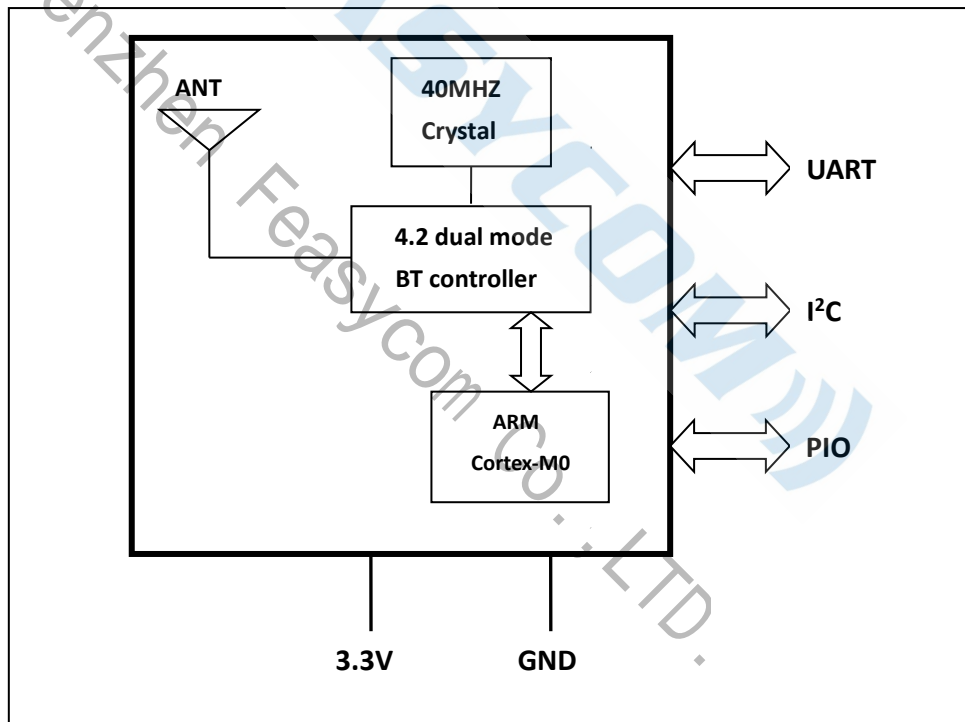

Figure 1

1.2 Feature

- ◆ Fully qualified Bluetooth 4.2/4.0/3.0/2.1/2.0/1.2/1.1
- ◆ Postage stamp sized form factor.
- ◆ Low power.
- ◆ Class 1.5 support(high output power)
- ◆ The default UART Baud rate is 115.2Kbps and can support from 1200bps up to 921.6Kbps,.
- ◆ UART, I²C data connection interfaces.
- ◆ Support the OTA upgrade.
- ◆ Bluetooth stack profiles support: SPP, HID, MAP, and all BLE protocols.

1.3 Application

- ◆ Smart Watch and Bluetooth Bracelet
- ◆ Health & Medical devices
- ◆ Wireless POS
- ◆ Measurement and monitoring systems
- ◆ Industrial sensors and controls
- ◆ Asset Tracking

2. GENERAL SPECIFICATION

General Specification	
Chipset	Realtek RTL8761
Product	FSC-BT826F
Dimension	13mm x 26.9mm x 2.4mm
Bluetooth Specification	Bluetooth V4.2 (Dual Mode)
Power Supply	3.3V
Output Power	5.5 dBm
Sensitivity	-82dBm@0.1%BER
Frequency Band	2.402GHz -2.480GHz ISM band
Modulation	GFSK, $\pi/4$ -DQPSK, 8-DPSK
Baseband Crystal OSC	40MHz
Hopping & channels	1600hops/sec, 1MHz channel space,79 Channels(BT 4.2 to 2MHz channel space)
RF Input Impedance	50 ohms
Antenna	Onboard antenna
Interface	Data: UART, I ² C
Profile	SPP, GATT(BLE Standard) MFI,Airsync,ANCS, iBeacon, MAP(optional),OTA(optional)
Temperature	0°C to +70 °C
Humidity	10%~95% Non-Condensing
Environmental	RoHS Compliant

Table 1

3. PHYSICAL CHARACTERISTIC

FSC-BT826F dimension is 26.9mm(L) x 13mm(W) x 2.4mm(H).

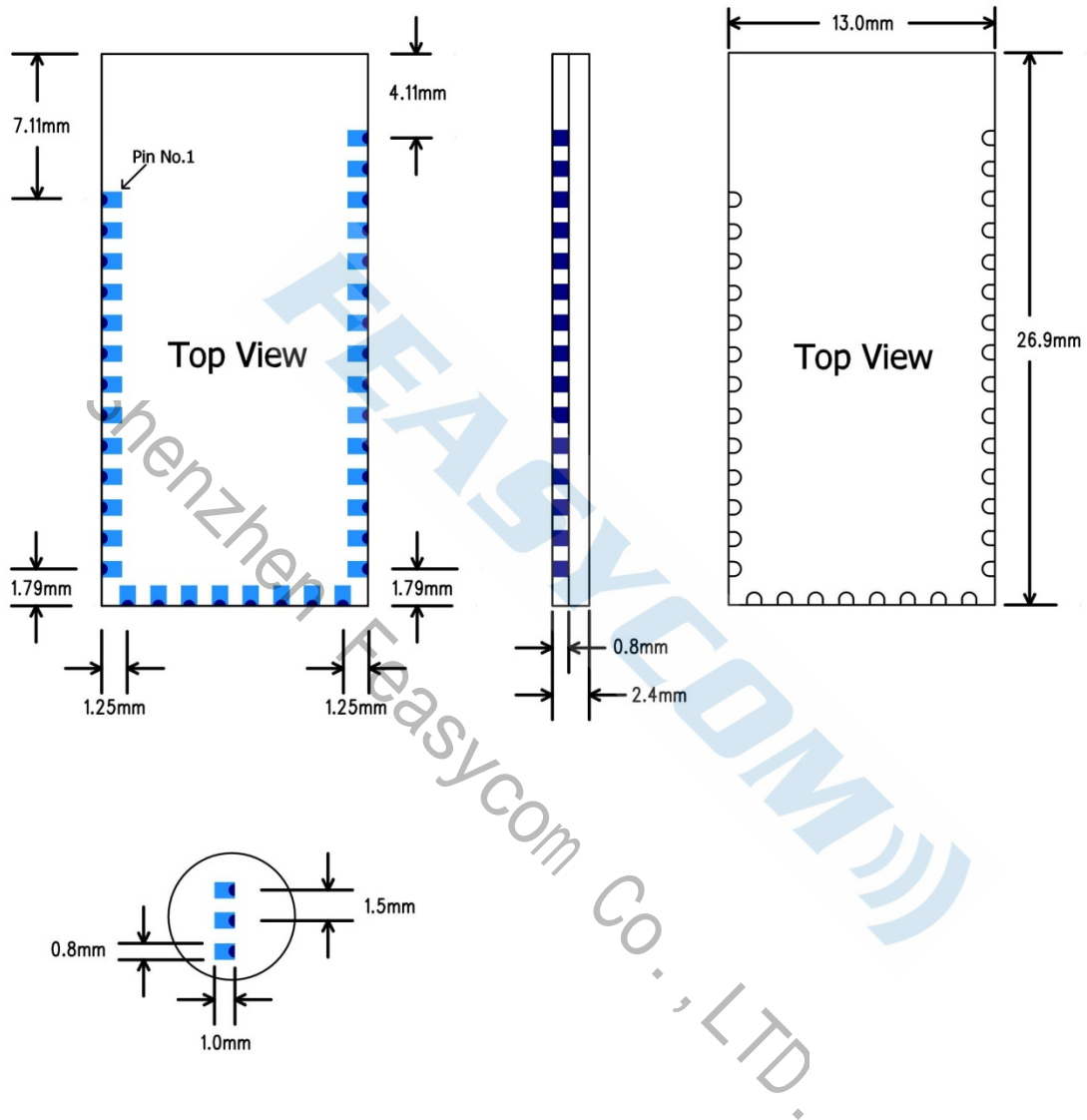

Figure 2: Package Dimensions (TOP VIEW)

4. PIN DEFINITION DESCRIPTIONS

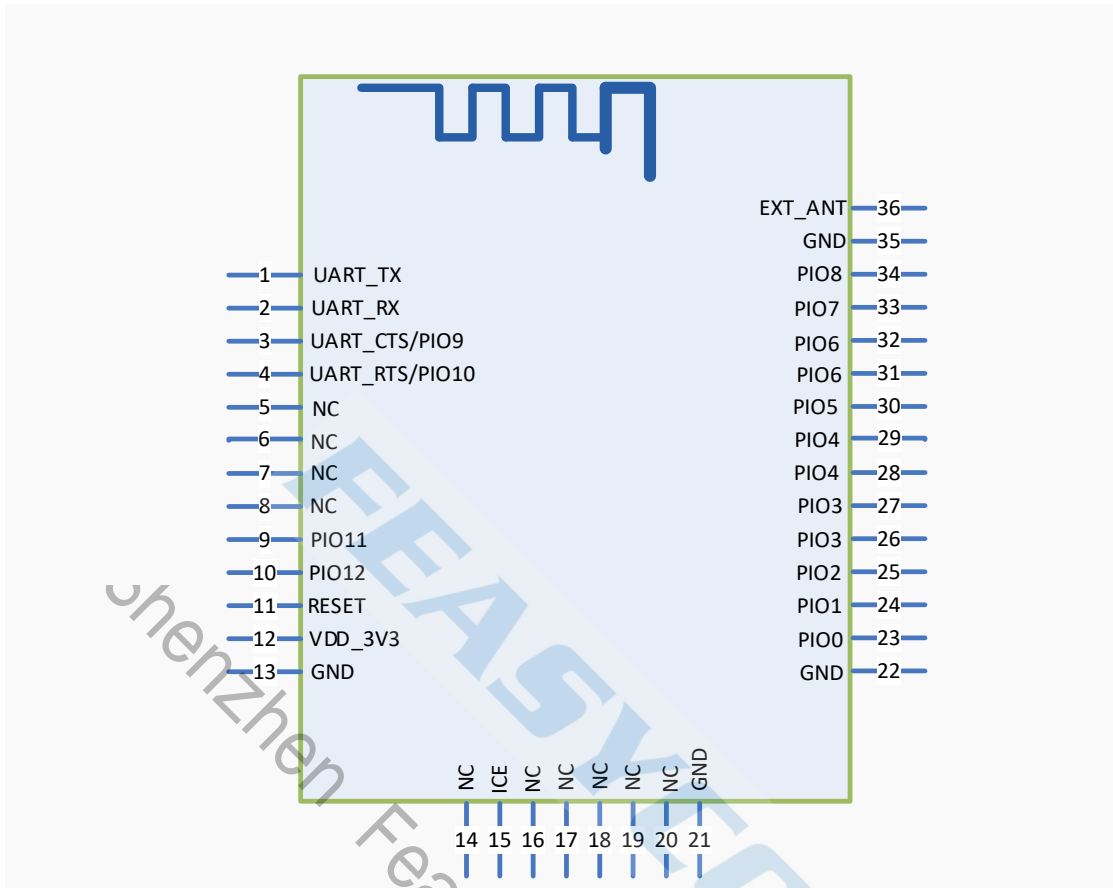

Figure 3: PIN description

Pin	Pin Name	Pad Type	Description
1	UART_TX	CMOS output	UART data output
2	UART_RX	CMOS input	UART data input
3	UART_CTS/PIO9	CMOS input	UART clear to send active low Alternative Function: Programmable input/output line
4	UART_RTS/PIO10	CMOS output	UART request to send active low Alternative Function: Programmable input/output line
5	NC		
6	NC		
7	NC		
8	NC		
9	PIO11	I/O	Programmable input/output line

10	PIO12	I/O	Programmable input/output line
11	RESET		Reset Pin
12	VDD_3V3	VDD	Power supply voltage 3.3V
13	GND	VSS	Power Ground
14	NC		
15	ICE		Debug port, Tx & Rx
16	NC		
17	NC		
18	NC		
19	NC		
20	NC		
21	GND	VSS	Power Ground
22	GND	VSS	Power Ground
23	PIO0	I/O	Programmable input/output line
24	PIO1	I/O	Programmable input/output line
25	PIO2	I/O	Programmable input/output line
26	PIO3	I/O	Programmable input/output line
27	PIO3	I/O	Programmable input/output line
28	PIO4	I/O	Programmable input/output line
29	PIO4	I/O	Programmable input/output line
30	PIO5	I/O	Programmable input/output line
31	PIO6	I/O	Programmable input/output line Alternative Function: LED(Default)
32	PIO6	I/O	Programmable input/output line Alternative Function: LED(Default)
33	PIO7	I/O	Programmable input/output line Alternative Function: BT Status(Default)
34	PIO8	I/O	Programmable input/output line
35	GND	VSS	Power Ground
36	EXT_ANT	O	External antenna interface

Table 2

5. Interface Characteristics

5.1 UART Interface

Four signals are used to implement the UART function. When FSC-BT826F is connected to another digital device, UART_RX and UART_TX transfer data between the two devices. The remaining two signals, UART_CTS and UART_RTS, can be used to implement RS232 hardware flow control where both are active low indicators.

The interface consists of four-line connection as described in below:

Signal name	Driving source	Description
UART-TX	FSC-BT826F module	Data from FSC-BT826F module
UART-RX	Host	Data from Host
UART-RTS	FSC-BT826F module	Request to send output of FSC-BT826F module
UART-CTS	Host	Clear to send input of FSC-BT826F module

Table 3

Default Data Format

Property	Possible Values
BCSP-Specific Hardware	Enable
Baud Rate	115.2 Kbps
Flow Control	None
Data bit length	8bit
Parity	None
Number of Stop Bits	1

Table 4

6. RECOMMENDED TEMPERATURE REFLOW PROFILE

The re-flow profiles are illustrated in Figure 11 and Figure 12 below.

- Follow: IPC/JEDEC J-STD-020 C
- Condition:
 - Average ramp-up rate(217°C to peak):1~2°C/sec max.
 - Preheat:150~200C,60~180 seconds
 - Temperature maintained above 217°C:60~150 seconds
 - Time within 5°C of actual peak temperature:20~40 sec.
 - Peak temperature:250+0/-5°C or 260+0/-5°C
 - Ramp-down rate:3°C/sec.max.

- Time 25°C to peak temperature: 8 minutes max
- Cycle interval: 5 minus

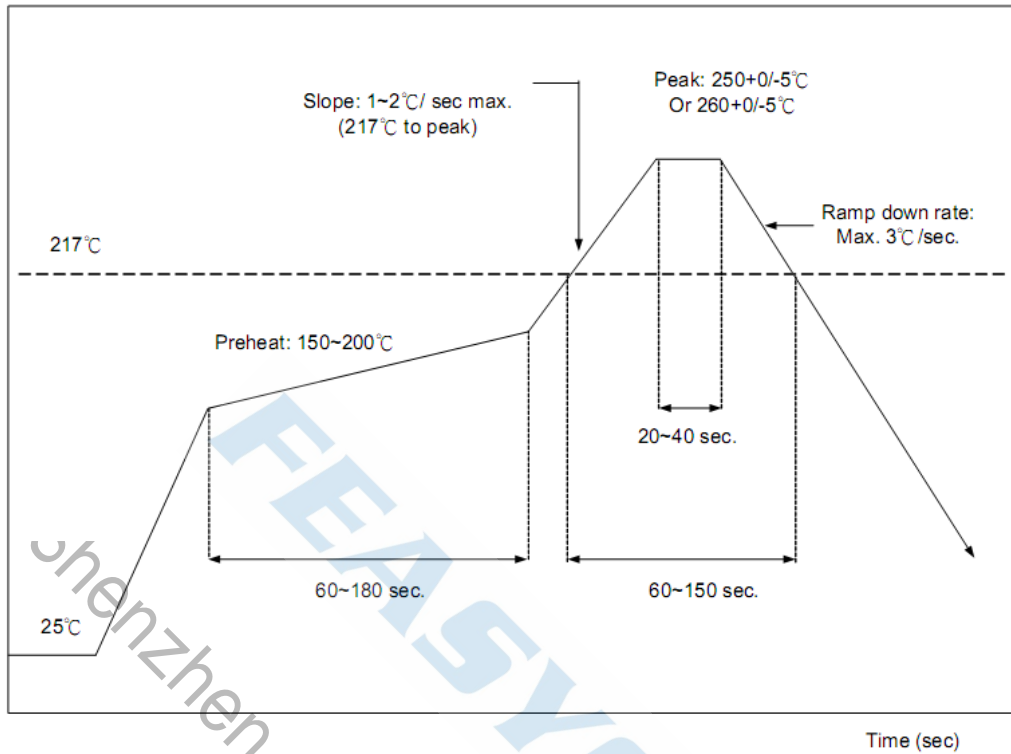

Figure 4: Typical Lead-free Re-flow Solder Profile

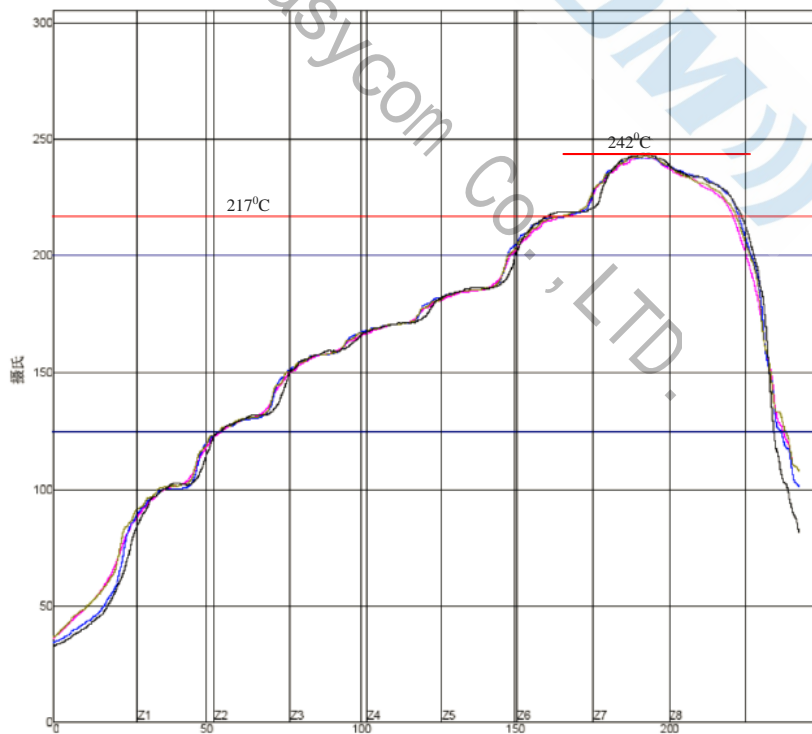

Figure 5 : Typical Lead-free Re-flow

The soldering profile depends on various parameters according to the use of different solder and

material. The data here is given only for guidance on solder re-flow.

FSC-BT826F will withstand up to two re-flows to a maximum temperature of 245°C.

7. Reliability and Environmental Specification

7.1 Temperature test

Put the module in demo board which uses exit power supply, power on the module and connect to mobile. Then put the demo in the 0°C space for 1 hour and then move to +70°C space within 1 minute, after 1 hour move back to 0°C space within 1 minute. This is 1 cycle. The cycles are 32 times and the units have to pass the testing.

7.2 Vibration Test

The module is being tested without package. The displacement requests 1.5mm and sample is vibrated in three directions(X,Y,Z).Vibration frequency set as 0.5G , a sweep rate of 0.1 octave/min from 5Hz to 100Hz last for 90 minutes each direction. Vibration frequency set as 1.5G, a sweep rate of 0.25 octave/min from 100Hz to 500Hz last for 20 minutes each direction.

7.3 Desquamation test

Use clamp to fix the module, measure the pull of the component in the module, make sure the module's soldering is good.

7.4 Drop test

Free fall the module (condition built in a wrapper which can defend ESD) from 150cm height to cement ground, each side twice, total twelve times. The appearance will not be damaged and all functions OK.

7.5 Packaging information

After unpacking, the module should be stored in environment as follows:

- Temperature: 25°C \pm 2°C
- Humidity: <60%
- No acidity, sulfur or chlorine environment

The module must be used in four days after unpacking.

8. Layout and Soldering Considerations

8.1 Soldering Recommendations

FSC-BT826F is compatible with industrial standard reflow profile for Pb-free solders. The reflow profile used is dependent on the thermal mass of the entire populated PCB, heat transfer efficiency of the oven and particular type of solder paste used. Consult the datasheet of particular solder paste for profile configurations.

Feasycom will give following recommendations for soldering the module to ensure reliable solder joint and operation of the module after soldering. Since the profile used is process and layout dependent, the optimum profile should be studied case by case. Thus following recommendation should be taken as a starting point guide.

8.2 Layout Guidelines

It is strongly recommended to use good layout practices to ensure proper operation of the module. Placing copper or any metal near antenna deteriorates its operation by having effect on the matching properties. Metal shield around the antenna will prevent the radiation and thus metal case should not be used with the module. Use grounding vias separated max 3 mm apart at the edge of grounding areas to prevent RF penetrating inside the PCB and causing an unintentional resonator. Use GND vias all around the PCB edges.

The mother board should have no bare conductors or vias in this restricted area, because it is not covered by stop mask print. Also no copper (planes, traces or vias) are allowed in this area, because of mismatching the on-board antenna.

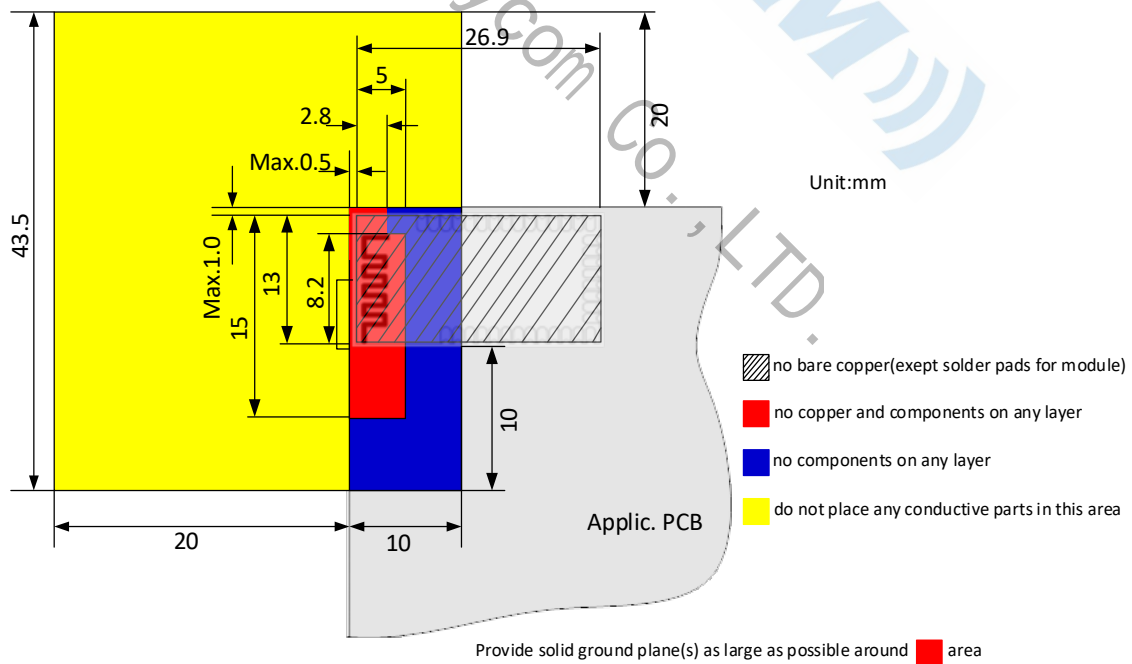

Figure 6: FSC-BT826F Restricted Area

Following recommendations helps to avoid EMC problems arising in the design. Note that each design is unique and the following list do not consider all basic design rules such as avoiding capacitive coupling between signal lines. Following list is aimed to avoid EMC problems caused by RF part of the module. Use good consideration to avoid problems arising from digital signals in the design.

Ensure that signal lines have return paths as short as possible. For example if a signal goes to an inner layer through a via, always use ground vias around it. Locate them tightly and symmetrically around the signal vias. Routing of any sensitive signals should be done in the inner layers of the PCB. Sensitive traces should have a ground area above and under the line. If this is not possible, make sure that the return path is short by other means (for example using a ground line next to the signal line).

FEASYCOM)))
Shenzhen Feasycom Co., LTD.

9. Application Schematic

