



FSC-BT955

Bluetooth 5.2 Dual Mode Module Datasheet

Version 1.1

Copyright © 2013-2022 Feasycom Technology. All Rights Reserved.

Feasycom Technology reserves the right to make corrections, modifications, and other changes to its products, documentation and services at anytime. Customers should obtain the newest relevant information before placing orders. To minimize customer product risks, customers should provide adequate design and operating safeguards. Without written permission from Feasycom Technology, reproduction, transfer, distribution or storage of part or all of the contents in this document in any form is prohibited.

Revision History

Version	Date	Notes	
1.0	2022/05/10	Initial Version	luzhu
1.1	2022/05/19	Update module picture	luzhu

Contact Us

Shenzhen Feasycom Technology Co.,LTD

Email: sales@feasycom.com

Address: Rm 508, Building A, Fenghuang Zhigu, No.50, Tiezai Road,
Xixiang ,Baoan District,Shenzhen,518100,China.

Tel: 86-755-27924639,86-755-23062695

Contents

- 1. INTRODUCTION 4**
- 2. GENERAL SPECIFICATION 5**
- 3. HARDWARE SPECIFICATION 6**
 - 3.1 BLOCK DIAGRAM AND PIN DIAGRAM 6
 - 3.2 PIN DEFINITION DESCRIPTIONS 7
- 4. PHYSICAL INTERFACE 8**
 - 4.1 POWER MANAGEMENT 8
 - 4.1.1 Power Supply 8
 - 4.1.2 Battery Charger 8
 - 4.2 AUDIO PERIPHERALS 8
 - 4.3 USB INTERFACE 8
 - 4.4 I²S INTERFACE 8
 - 4.5 SERIAL INTERFACES 9
 - 4.5.1 UART Interface 9
 - 4.5.2 I²C Interface 10
- 5. ELECTRICAL CHARACTERISTICS 10**
 - 5.1 ABSOLUTE MAXIMUM RATINGS 10
 - 5.2 RECOMMENDED OPERATING CONDITIONS 11
 - 5.3 BATTERY CHARGER 11
 - 5.4 AUDIO CHARACTERISTICS 11
 - 5.4.1 Analogue to Digital Converter 11
 - 5.4.2 Digital to Analogue Converter 12
- 6. MSL &ESD PROTECTION 12**
- 7. RECOMMENDED TEMPERATURE REFLOW PROFILE 12**
- 8. FSC-BT955 MECHANICAL DETAILS 14**
- 9. HARDWARE INTEGRATION SUGGESTIONS 15**
 - 9.1 SOLDERING RECOMMENDATIONS 15
 - 9.2 LAYOUT GUIDELINES(INTERNAL ANTENNA) 15
 - 9.3 LAYOUT GUIDELINES(EXTERNAL ANTENNA) 16
 - 9.3.1 Antenna Connection and Grounding Plane Design 16
- 10. PRODUCT PACKAGING INFORMATION 17**
 - 10.1 DEFAULT PACKING 17
 - 10.2 PACKING BOX(OPTIONAL) 18
- 11. APPLICATION SCHEMATIC 19**

1. INTRODUCTION

Overview

FSC-BT955 is a Bluetooth dual-mode module series. It supports a Bluetooth Low Energy and BR/EDR compliant system for audio and data communication.

FSC-BT955 integrates an ultra-low-power DSP and application processor with embedded flash memory, a high-performance stereo codec, a power management subsystem, I²S, LED drivers and ADC I/O in a SoC IC.

By default, FSC-BT955 module is equipped with powerful and easy-to-use Feasycom firmware. It's easy to use and completely encapsulated. Feasycom firmware enables users to access Bluetooth functionality with simple ASCII commands delivered to the module over serial interface - it's just like a Bluetooth modem.

Therefore, FSC-BT955 provides an ideal solution for developers who want to integrate Bluetooth wireless technology into their design.

Features

- Bluetooth 5.2 classic and low energy
- Voice-activated assistant
- 24 bits audio quality
- 8 kHz to 384 kHz audio sample rate
- Acoustic echo cancellation
- MIC/Line_IN
- Battery Charge (<220mA)
- PCB ANT

Application

- Bluetooth speakers
- Bluetooth music box
- Stereo headsets/headphones
- USB audio/USB to Bluetooth dongle
- Audio transmitter

Module picture as below showing

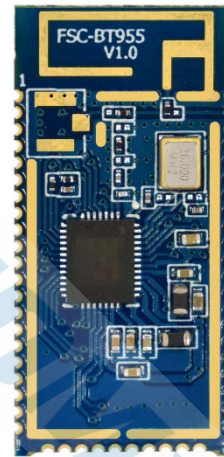

Figure 1: FSC-BT955 Picture

2. General Specification

Table 1: General Specifications

Categories	Features	Implementation
Wireless Specification	version	BT V5.2 Dual-mode
	Frequency	2.402 - 2.480 GHz
	Transmit Power	+10 dBm (Maximum)
	Receive Sensitivity	-93.0 dBm (typ.) BR=1Mbps -94.0 dBm (typ.) EDR=2Mbps -86.0 dBm (typ.) EDR=3Mbps -97 dBm (typ.) BLE=1Mbps
Host Interface and Peripherals	UART Interface	TX, RX
		General Purpose I/O
		Default 115200,N,8,1
		Baudrate support from 4800 to 4000000
	GPIO	17 (maximum – configurable) lines
	I ² C Interface	2 I ² C Master interface with speed up to 400 kbps
	ADC Interface	Analog input voltage range: 0~ 1.8V 12-bit ADC
USB Interface	1 full-speed (12Mbps)	
Profiles	BR/EDR	(Serial Port Profile) - Up to 600 Kbps A2DP/AVRCP/HFP/HSP/HOGP/PBAP/SPP Profiles support
	Bluetooth Low Energy	GATT Client & Peripheral Simultaneous BR/EDR and BLE support
Audio		24bit ADC/DAC
FW upgrade		UART
Supply Voltage	Supply	VDD: 2.8V~ 4.2V
Power Consumption		Shut down:0.9uA(typ)
		Standby:20uA(typ)
		A2DP/HFP:6mA(typ)
		BLE TX 10dBm:28mA(typ)
Environmental	Operating	-20°C to +85°C
	Storage	-40°C to +85°C
Miscellaneous	Lead Free	Lead-free and RoHS compliant
	Warranty	One Year
Humidity		10% ~ 90% non-condensing
MSL grade:		MSL 3
ESD grade:		Human Body Model: Class 2 2kV (all pins)
		Charged Device Model: Class 3 500 V (all pins)
Physical	Dimensions	13mm(W) x 26.9mm(L) x 1.7mm(H) Tolerance: ±0.2mm

3. HARDWARE SPECIFICATION

3.1 Block Diagram and PIN Diagram

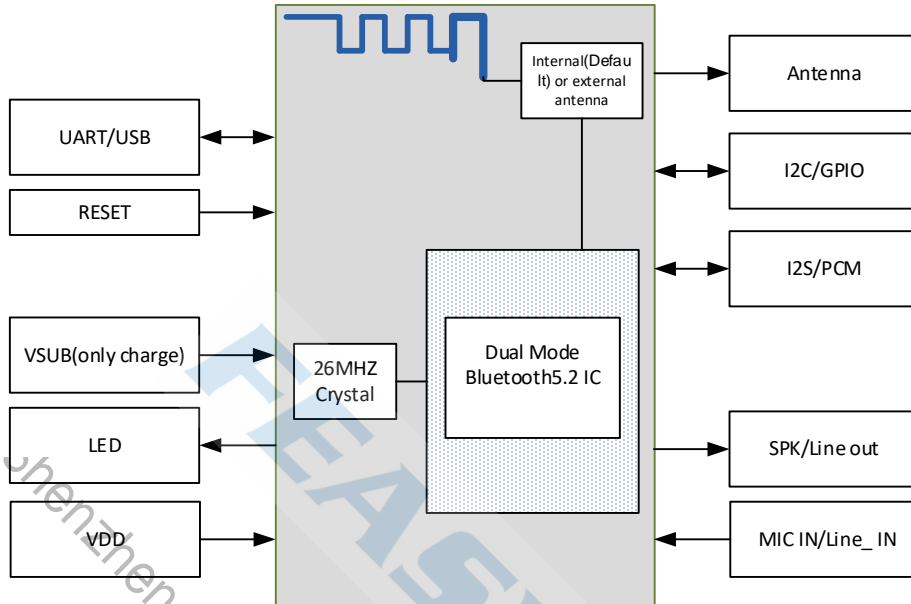

Figure 2: Block Diagram

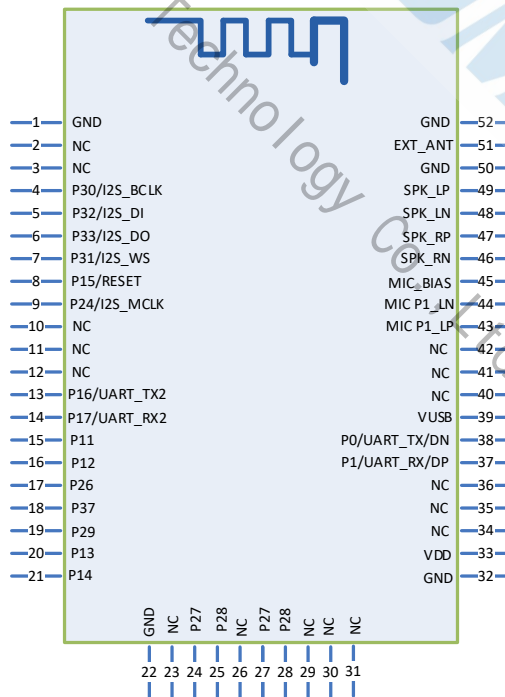

Figure 3: FSC-BT955 PIN Diagram(Top View)

3.2 PIN Definition Descriptions

Table 2: Pin definition

Pin Name	Pin Number	Type	Descriptions	Notes
P0/UART_TX/DN	38	I/O	GPIO0/UART_TX/USB_DN	
P1/UART_RX/DP	37	I/O	GPIO1/UART_RX/USB_DP	
P16/UART_TX2	13	I/O	GPIO16/UART_TX2	
P17/UART_RX2	14	I/O	GPIO17/UART_RX2	
P12	16	I/O	GPIO12	
P11	15	I/O	GPIO11	
P27	24,27	I/O	GPIO 27/PWM7	
P28	25,28	I/O	GPIO28/PWM8	
P29	19	I/O	GPIO29/ GREEN LED	
P37	18	I/O	GPIO37/ BLUE LED	
P15/RESET	8	I/O	GPIO15/RESET (Low level for more than 15ms)	
VUSB	39	VDD	+5V input	
VDD	33	VDD	Power Supplies (2.8~4.2V)	
GND	1,22,32,50,52	VSS	GND	
P14	21	I/O	GPIO14/ TDO	
MIC P1_LN	44	Audio	MIC LN input, negative	
MIC P1_LP	43	Audio	MIC LP input, positive	
MIC_BIAS	45	VDD	MIC Power Supplies	
SPK_LN	48	Audio	Headphone/speaker differential L output, negative	
SPK_LP	49	Audio	Headphone/speaker differential L output, positive	
SPK_RN	46	Audio	Headphone/speaker differential R output, negative	
SPK_RP	47	Audio	Headphone/speaker differential R output, positive	
P30/I2S_BCLK	4	I/O	GPIO30/ I2S_BCLK	
P32/ I2S_DI	5	I/O	GPIO32/ I2S_DI	
P33/ I2S_DO	6	I/O	GPIO33/ I2S_DO	
P31/ I2S_WS	7	I/O	GPIO31/ I2S_WS	
P24/ I2S_MCLK	9	I/O	GPIO24/ I2S_MCLK	
P26	17	I/O	GPIO26/ RED LED	
P13	20	I/O	GPIO13/ TDI	
EXT_ANT	51	ANT	External antenna	
NC	2,3,10~12,23,			
	29,30,31,34~36,			
	40,41,42			

4. PHYSICAL INTERFACE

4.1 Power Management

4.1.1 Power Supply

- The FSC- BT955 can be powered directly from a 2.8V to 4.2V external battery via the VDD pin or it can be powered from a 4.75V to 5.5V USB power supply via the VUSB pin. The VUSB can be also used to charge battery with internal charge control circuit.

4.1.2 Battery Charger

- The default mode for the FSC-BT955 battery charger is OFF.
- The internal charger circuit can provide up to 220mA of charge current.

4.2 Audio Peripherals

- The FSC- BT955 comes with a rich set of audio peripherals to enhance the Bluetooth listening experience. The chip includes 24 bits analog-to-digital converter (ADC) and 24 bits digital-to-analog converter (DAC), together with amplifier and bias. **The DAC is capable of driving 16 Ω speakers with up to 30 pF of load capacitance .**
- The typical sample rate of ADC and DAC is to 8 kHz, 44.1 kHz and 48 kHz, but could be set to any number from 8 kHz to 384 kHz.
- There is also digital microphone interface to support up to 1 digital microphone. The PDM does the 8:1 CIC decimation that the PCM sample rate could be up to 384 kHz when the PDM clock frequency is 3.072 MHz.

4.3 USB interface

- The USB interface supports both host and device mode, with full speed.

4.4 I²S interface

- The I²S interface supports both master and slave mode, with sample rate from 7.35 kHz to 384 kHz.
- There is an I²S DPLL dedicate for I²S and audio ADC/DAC, that it can output master clock for external device.

4.5 Serial Interfaces

4.5.1 UART Interface

FSC-BT955 provides one channels of Universal Asynchronous Receiver/Transmitters(UART)(Full-duplex asynchronous communications). The UART Controller performs a serial-to-parallel conversion on data received from the peripheral and a parallel-to-serial conversion on data transmitted from the CPU. Each UART Controller channel supports ten types of interrupts.

This is a standard UART interface for communicating with other serial devices. The UART interface provides a simple mechanism for communicating with other serial devices using the RS232 protocol.

When the module is connected to another digital device, UART_RX and UART_TX transfer data between the two devices.

This module output is at 3.3V CMOS logic levels (tracks VCC). Level conversion must be added to interface with an RS-232 level compliant interface.

Table 3: Possible UART Settings

Parameter	Possible Values	
Baudrate	Minimum	4800 baud ($\leq 2\%$ Error)
	Standard	115200bps($\leq 1\%$ Error)
	Maximum	4Mbaud($\leq 1\%$ Error)
Parity	None, Odd or Even	
Number of stop bits	1 / 2	
Bits per channel	8	

When connecting the module to a host, please make sure to follow .

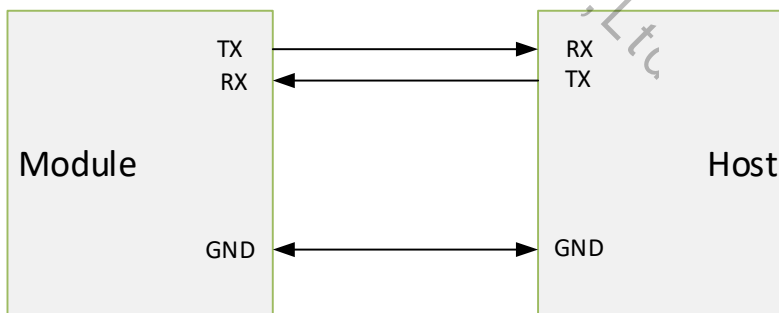

Figure 4: UART Connection

4.5.2 I²C Interface

FSC-BT955 includes a configurable I²C interface.

I²C is a two-wire, bi-directional serial bus that provides a simple and efficient method of data exchange between devices. The I²C standard is a true multi-master bus including collision detection and arbitration that prevents data corruption if two or more masters attempt to control the bus simultaneously.

Data is transferred between a Master and a Slave synchronously to SCL on the SDA line on a byte-by-byte basis. Each data byte is 8-bit long. There is one SCL clock pulse for each data bit with the MSB being transmitted first. An acknowledge bit follows each transferred byte. Each bit is sampled during the high period of SCL; therefore, the SDA line may be changed only during the low period of SCL and must be held stable during the high period of SCL. A transition on the SDA line while SCL is high is interpreted as a command (START or STOP). Please refer to the following figure for more details about I²C Bus Timing.

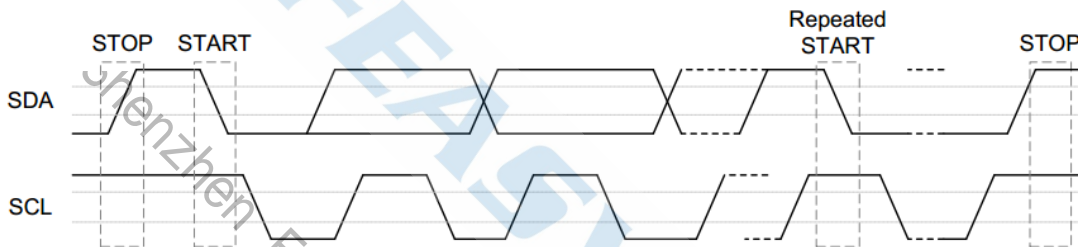

Figure 5: I2C Bus Timing

The device on-chip I²C logic provides the serial interface that meets the I²C bus standard mode specification. The I²C port handles byte transfers autonomously. The I²C H/W interfaces to the I²C bus via two pins: SDA and SCL. Pull up resistor is needed for I²C operation as these are open drain pins. When the I/O pins are used as I²C port, user must set the pins function to I²C in advance

5. ELECTRICAL CHARACTERISTICS

5.1 Absolute Maximum Ratings

Absolute maximum ratings for supply voltage and voltages on digital and analogue pins of the module are listed below. Exceeding these values causes permanent damage.

The average GPIO pin output current is defined as the average current value flowing through any one of the corresponding pins for a 100mS period. The total average GPIO pin output current is defined as the average current value flowing through all of the corresponding pins for a 100mS period. The maximum output current is defined as the value of the peak current flowing through any one of the corresponding pins.

Table 4: Absolute Maximum Rating

Parameter	Min	Max	Unit
VUSB	4.75	5.5	V
VDD	2.8	4.2	V
T _{ST} - Storage Temperature	-40	+85	°C

(a) Standard maximum input voltage is 5.75V, a 6.50V maximum depends on firmware version and implementation of over-temperature protection software, for more information contact Feasycom.
 (b) VDD is the VDD_IO supply domain for this I/O. Voltage must not exceed 3.6 V on any I/O.

5.2 Recommended Operating Conditions

Table 5:Recommended Operating Conditions

Parameter	Min	Type	Max	Unit
VUSB	4.75	5	5.5	V
VDD	2.8	3.3	4.2	V
T _A - Operating Temperature	-20	-	+85	°C

5.3 Battery Charger

Table 6: Battery Charger

Parameter	Min	Type	Max	Unit
Input voltage, VUSB	4.75	5.00	5.5	V
Trickle Charge Mode Charge Current at trickle mode as percent of fast charge mode)		10%		
Fast Charge Mode Charge current at fast charge mode	5		220	mA
V _{end} (Need Calibrated) VBAT voltage when Charge End		4.2		V

5.4 Audio Characteristics

5.4.1 Analogue to Digital Converter

Table 7:Analogue to Digital Converter (single-ended/differential audio input)

Parameter	Cconditions	Min	Type	Max	Unit
Resolution	-	-	-	24	Bits
Output Sample Rate, F _{sample}	-	8	-	384	KHz
Input level		-		2.8	V _{pk-pk}
SNR	1KHz sine wave	-	100	-	dB

5.4.2 Digital to Analogue Converter

Table 8: Digital to Analogue Converter (differential audio output)

Parameter	Ccnditions	Min	Type	Max	Unit
DAC Diff. Output	With 600ohm loading	-	-	1.1	Vrms
Amplitude	With 16ohm loading	-	-	0.9	Vrms
SNR	1kHz sine wave		104		dB

6. MSL &ESD Protection

Table 9: MSL and ESD

Parameter	Class	Max Rating
MSL grade(with JEDEC J-STD-020)		MSL 3
Human Body Model Contact Discharge per ANSI/ESDA/JEDEC JS-001	2	2kV(all pins)
Charged Device Model Contact Discharge per JEDEC/EIA JESD22-C101	3	500V (all pins)

7. RECOMMENDED TEMPERATURE REFLOW PROFILE

Prior to any reflow, it is important to ensure the modules were packaged to prevent moisture absorption. New packages contain desiccate (to absorb moisture) and a humidity indicator card to display the level maintained during storage and shipment. If directed to bake units on the card, please check the below **Table 10** and follow instructions specified by IPC/JEDEC J-STD-033.

Note: The shipping tray cannot be heated above 65°C. If baking is required at the higher temperatures displayed in the below **Table 10**, the modules must be removed from the shipping tray.

Any modules not manufactured before exceeding their floor life should be re-packaged with fresh desiccate and a new humidity indicator card. Floor life for MSL (Moisture Sensitivity Level) 3 devices is 168 hours in ambient environment 30°C/60%RH.

Table 10: Recommended baking times and temperatures

MSL	125°C Baking Temp.		90°C/≤ 5%RH Baking Temp.		40°C/ ≤ 5%RH Baking Temp.	
	Saturated @ 30°C/85%	Floor Life Limit + 72 hours @ 30°C/60%	Saturated @ 30°C/85%	Floor Life Limit + 72 hours @ 30°C/60%	Saturated@ 30°C/85%	Floor Life Limit + 72 hours @ 30°C/60%
3	9 hours	7 hours	33 hours	23 hours	13 days	9 days

Feasycom surface mount modules are designed to be easily manufactured, including reflow soldering to a PCB. Ultimately it is the responsibility of the customer to choose the appropriate solder paste and to ensure oven temperatures during reflow meet the requirements of the solder paste. Feasycom surface mount modules conform to J-STD-020D1 standards for reflow temperatures.

The soldering profile depends on various parameters necessitating a set up for each application. The data here is given only for guidance on solder reflow.

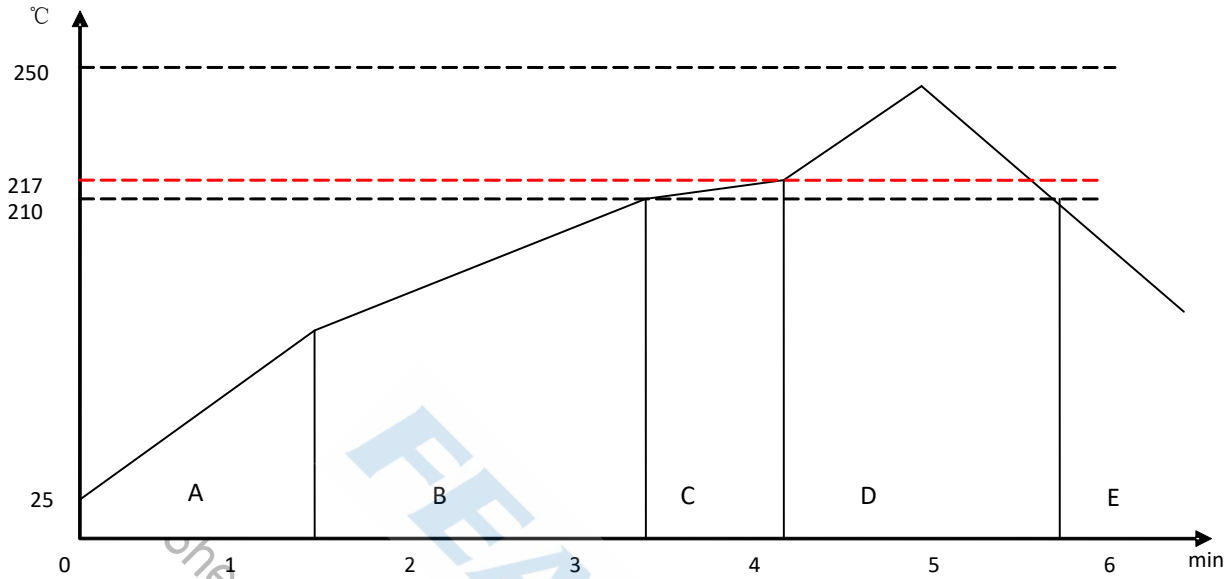

Figure 6: Typical Lead-free Re-flow

Pre-heat zone (A) — This zone raises the temperature at a controlled rate, **typically 0.5 – 2 °C/s**. The purpose of this zone is to preheat the PCB board and components to 120 ~ 150 °C. This stage is required to distribute the heat uniformly to the PCB board and completely remove solvent to reduce the heat shock to components.

Equilibrium Zone 1 (B) — In this stage the flux becomes soft and uniformly encapsulates solder particles and spread over PCB board, preventing them from being re-oxidized. Also with elevation of temperature and liquefaction of flux, each activator and rosin get activated and start eliminating oxide film formed on the surface of each solder particle and PCB board. **The temperature is recommended to be 150° to 210° for 60 to 120 second for this zone.**

Equilibrium Zone 2 (C) (optional) — In order to resolve the upright component issue, it is recommended to keep the temperature in 210 – 217 ° for about 20 to 30 second.

Reflow Zone (D) — The profile in the figure is designed for Sn/Ag3.0/Cu0.5. It can be a reference for other lead-free solder. The peak temperature should be high enough to achieve good wetting but not so high as to cause component discoloration or damage. Excessive soldering time can lead to intermetallic growth which can result in a brittle joint. The recommended peak temperature (Tp) is 230 ~ 250 °C. The soldering time should be 30 to 90 second when the temperature is above 217 °C.

Cooling Zone (E) — The cooling rate should be fast, to keep the solder grains small which will give a longer-lasting joint. **Typical cooling rate should be 4 °C.**

8. FSC-BT955 Mechanical Details

- Dimension: 13mm(W) x 26.9mm(L) x 1.7mm(H) Tolerance: $\pm 0.2\text{mm}$
- Module size: 13mm X 26.9mm Tolerance: $\pm 0.2\text{mm}$
- Pad size: 1.6mmX0.6mm Tolerance: $\pm 0.2\text{mm}$
- Pad pitch: 1.0mm Tolerance: $\pm 0.1\text{mm}$

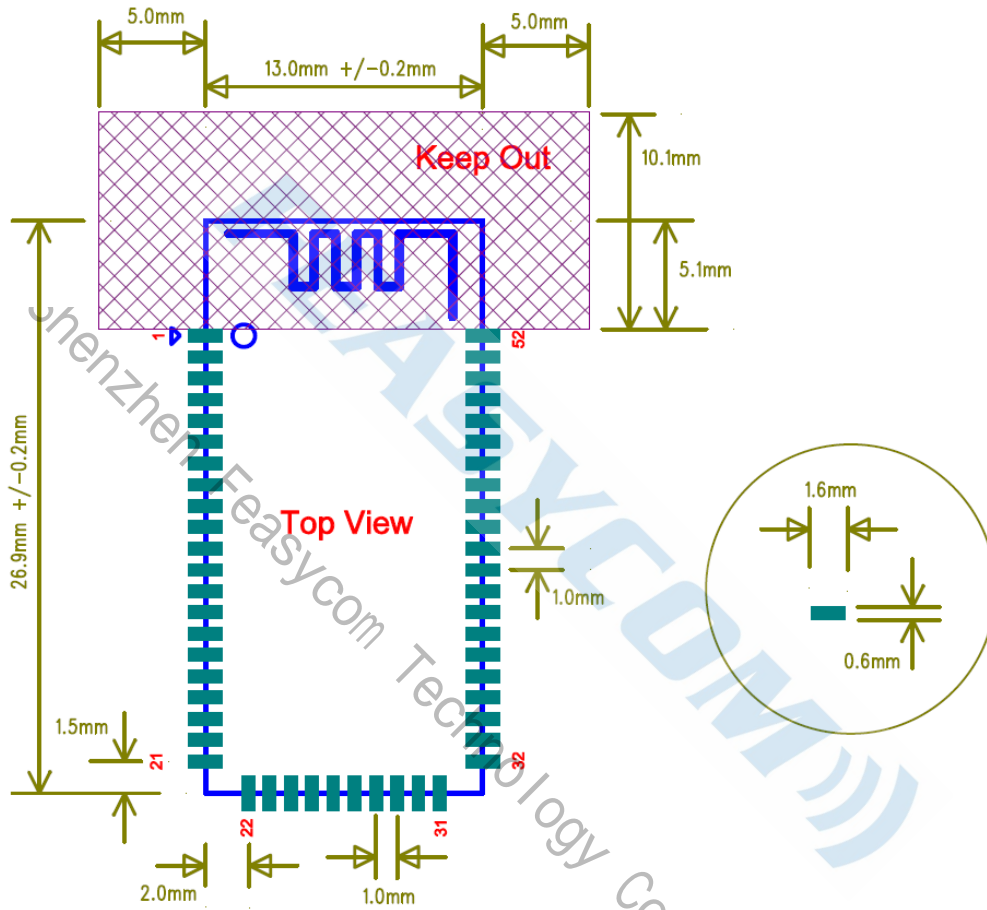

Figure 7: FSC-BT955 footprint

9. HARDWARE INTEGRATION SUGGESTIONS

9.1 Soldering Recommendations

FSC-BT955 is compatible with industrial standard reflow profile for Pb-free solders. The reflow profile used is dependent on the thermal mass of the entire populated PCB, heat transfer efficiency of the oven and particular type of solder paste used. Consult the datasheet of particular solder paste for profile configurations.

Feasycom will give following recommendations for soldering the module to ensure reliable solder joint and operation of the module after soldering. Since the profile used is process and layout dependent, the optimum profile should be studied case by case. Thus following recommendation should be taken as a starting point guide.

9.2 Layout Guidelines(Internal Antenna)

It is strongly recommended to use good layout practices to ensure proper operation of the module. Placing copper or any metal near antenna deteriorates its operation by having effect on the matching properties. Metal shield around the antenna will prevent the radiation and thus metal case should not be used with the module. Use grounding vias separated max 3 mm apart at the edge of grounding areas to prevent RF penetrating inside the PCB and causing an unintentional resonator. Use GND vias all around the PCB edges.

The mother board should have no bare conductors or vias in this restricted area, because it is not covered by stop mask print. Also no copper (planes, traces or vias) are allowed in this area, because of mismatching the on-board antenna.

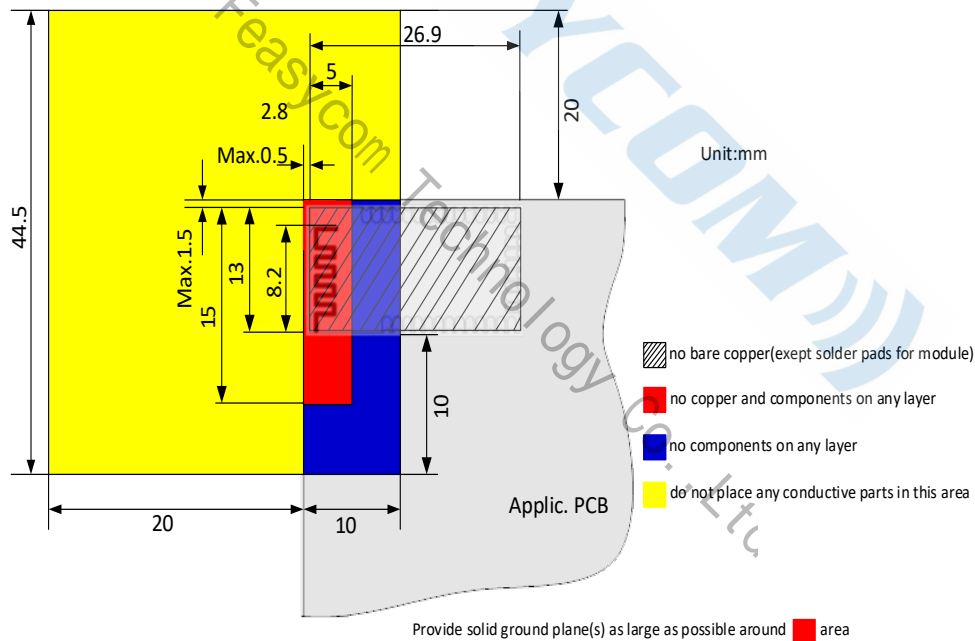

Figure 8: FSC-BT955 Restricted Area

Following recommendations helps to avoid EMC problems arising in the design. Note that each design is unique and the following list do not consider all basic design rules such as avoiding capacitive coupling between signal lines. Following list is aimed to avoid EMC problems caused by RF part of the module. Use good consideration to avoid problems arising from digital signals in the design.

Ensure that signal lines have return paths as short as possible. For example if a signal goes to an inner layer through a via, always use ground vias around it. Locate them tightly and symmetrically around the signal vias. Routing of any sensitive signals should be done in the inner layers of the PCB. Sensitive traces should have a ground area above and under the line. If this is not possible, make sure that the return path is short by other means (for example using a ground line next to the signal line).

9.3 Layout Guidelines(External Antenna)

Placement and PCB layout are critical to optimize the performances of a module without on-board antenna designs. The trace from the antenna port of the module to an external antenna should be 50Ω and must be as short as possible to avoid any interference into the transceiver of the module. The location of the external antenna and RF-IN port of the module should be kept away from any noise sources and digital traces. A matching network might be needed in between the external antenna and RF-IN port to better match the impedance to minimize the return loss.

As indicated in Figure 9 below, RF critical circuits of the module should be clearly separated from any digital circuits on the system board. All RF circuits in the module are close to the antenna port. The module, then, should be placed in this way that module digital part towards your digital section of the system PCB.

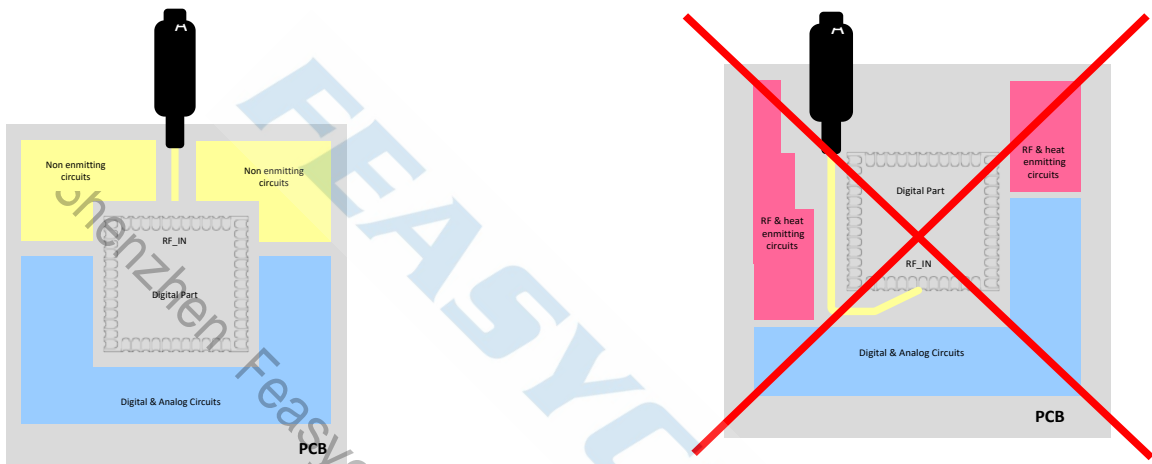

Figure 9: Placement the Module on a System Board

9.3.1 Antenna Connection and Grounding Plane Design

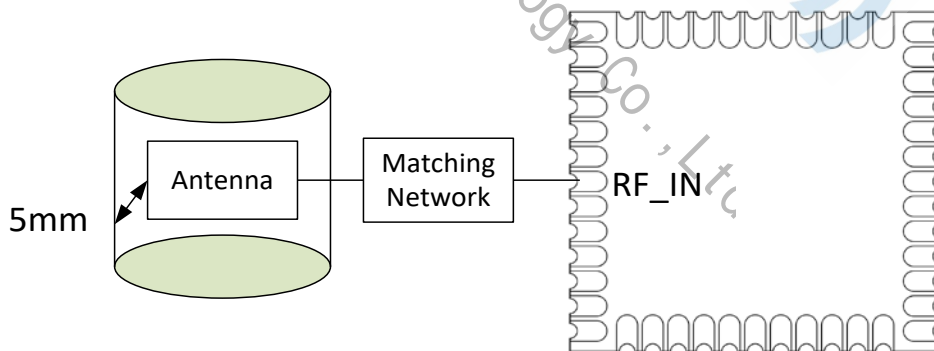

Figure 10: Leave 5mm Clearance Space from the Antenna

General design recommendations are:

- The length of the trace or connection line should be kept as short as possible.
- Distance between connection and ground area on the top layer should at least be as large as the dielectric thickness.
- Routing the RF close to digital sections of the system board should be avoided.
- To reduce signal reflections, sharp angles in the routing of the micro strip line should be avoided. Chamfers or fillets

are preferred for rectangular routing; 45-degree routing is preferred over Manhattan style 90-degree routing.

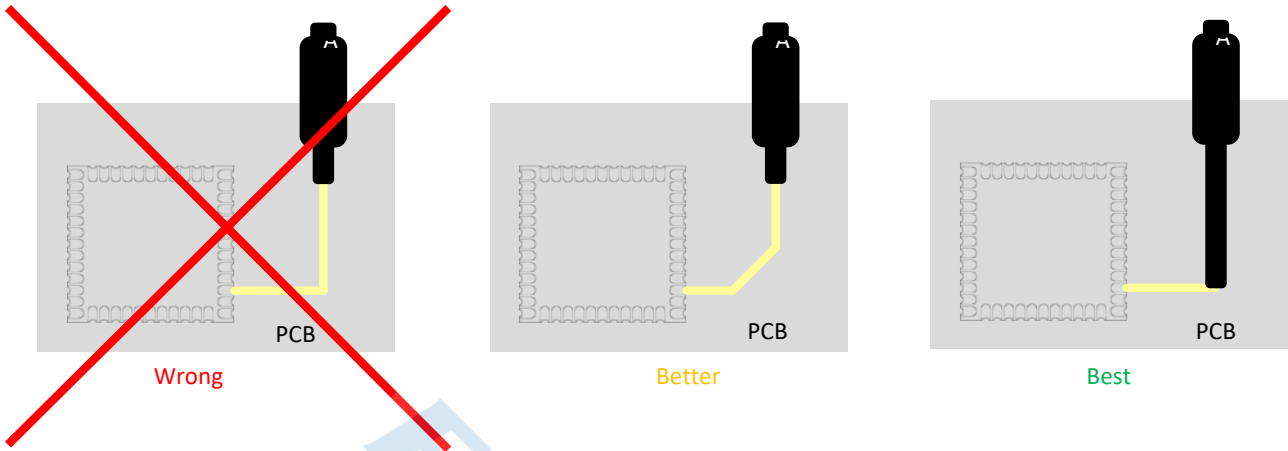

Figure 11: Recommended Trace Connects Antenna and the Module

- Routing of the RF-connection underneath the module should be avoided. The distance of the micro strip line to the ground plane on the bottom side of the receiver is very small and has huge tolerances. Therefore, the impedance of this part of the trace cannot be controlled.
- Use as many vias as possible to connect the ground planes.

10. PRODUCT PACKAGING INFORMATION

10.1 DefaultPacking

- a, Tray vacuum
- b, Tray Dimension: 180mm * 195mm





Figure 12: Tray vacuum

10.2 Packing box(Optional)

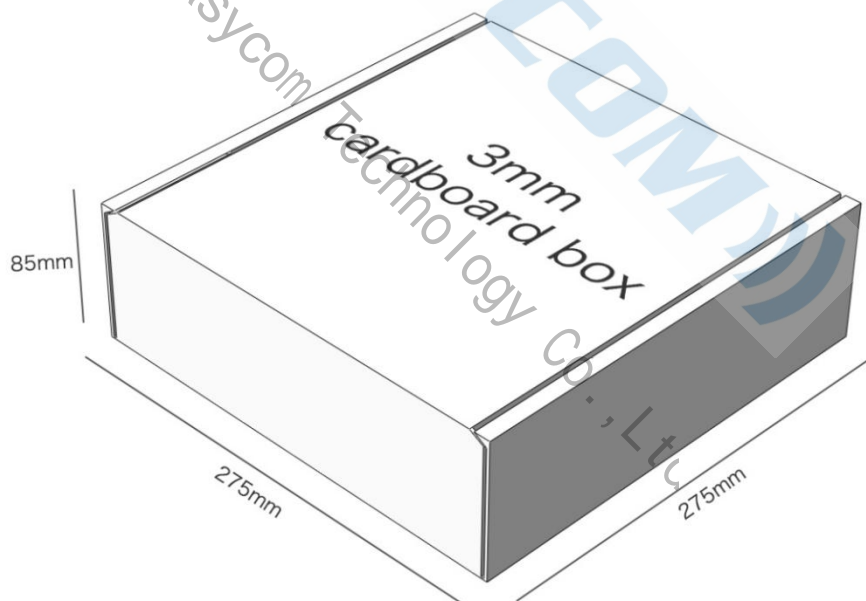

* If require any other packing, must be confirmed with customer

* Package: 2000PCS Per Carton (Min Carton Package)

Figure 13: Packing Box

11. APPLICATION SCHEMATIC

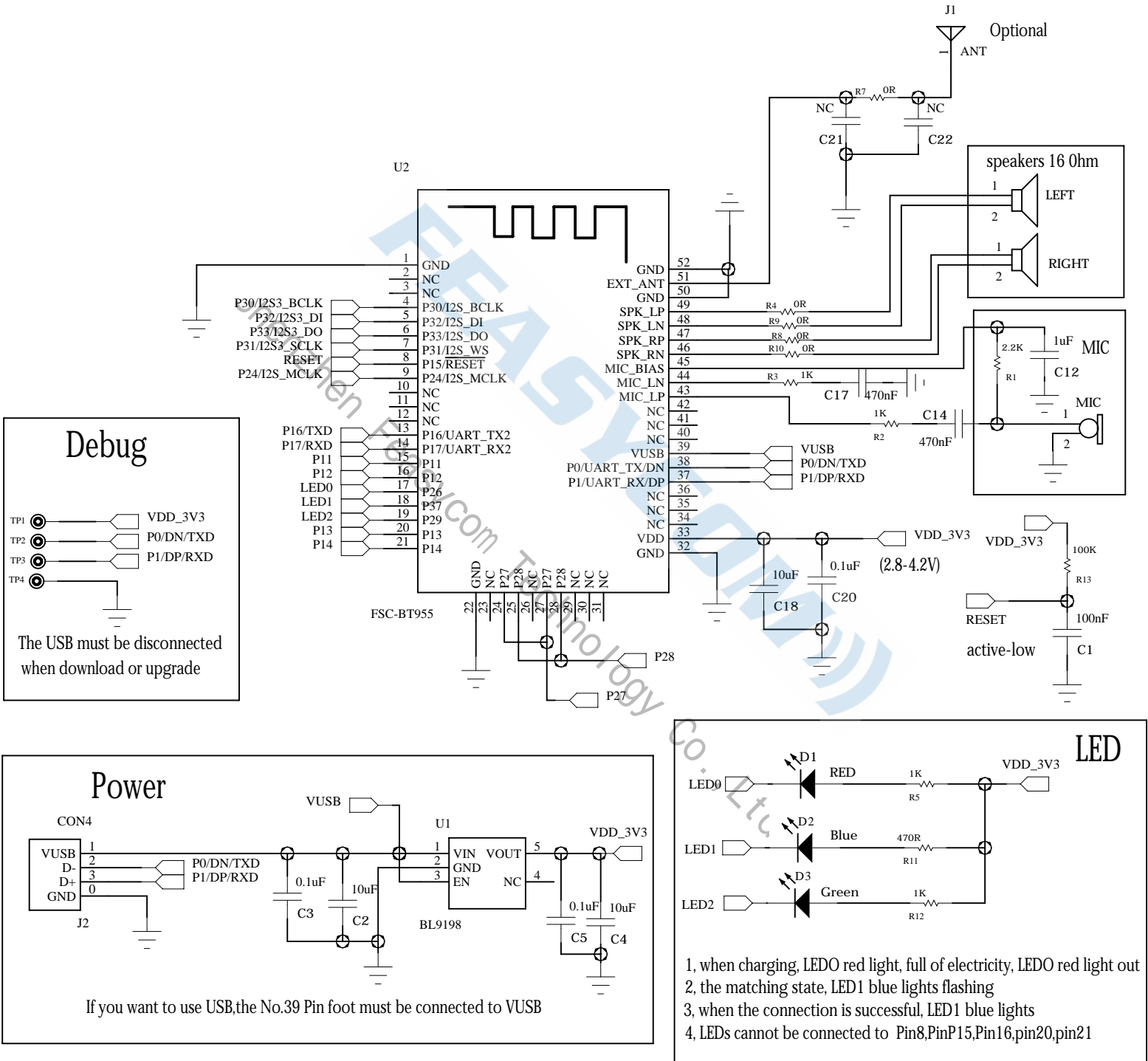

Debug

TP1 → VDD_3V3
 TP2 → P0/DN/TXD
 TP3 → P1/DP/RXD
 TP4 → GND

The USB must be disconnected when download or upgrade

Power

CON4: VUSB, D-, D+, GND

J2: VUSB, D-, D+, GND

U1: BL9198 (Voltage Regulator)

VIN, VOUT, GND, EN, NC

VDD_3V3

If you want to use USB, the No.39 Pin foot must be connected to VUSB

LED

LED0 → RED (1K resistor R5)

LED1 → Blue (470R resistor R11)

LED2 → Green (1K resistor R12)

VDD_3V3

- when charging, LED0 red light, full of electricity, LED0 red light out
- the matching state, LED1 blue lights flashing
- when the connection is successful, LED1 blue lights
- LEDs cannot be connected to Pin8, Pin15, Pin16, pin20, pin21